

Treuil à câble passant / Wire rope winch

Description

Description

Treuil à câble passant, CMU de 0,8 t à 3,2 t
Léger et rapide à mettre en place, sans limitation de la longueur de câble
Multiplications des capacités avec poulies de mouflage
Sécurité anti-débrayage et anti-surcharge

*Wire rope winch, WLL from 0,8 t to 3,2 t
Light and easy to install, with no restriction of the wire rope length
Increase capacity with deflection sheaves
Disconnection and overload protection*

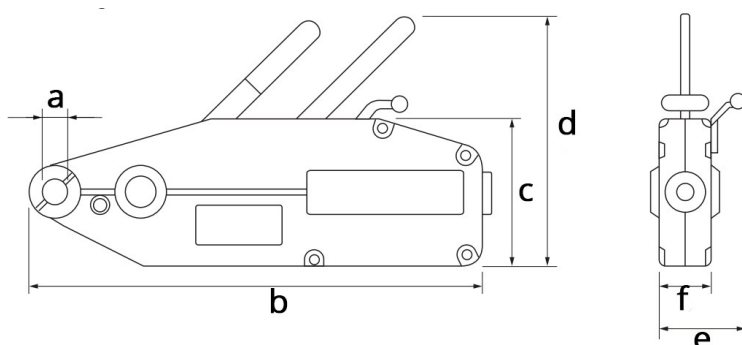

Réf. / Code : 200 661



Réf. / Code : 200 659



Réf. / Code : 200 660

RÉF. / CODE	REF. / CODE- CABLE COMPLET (20M)	CMU <u>WLL</u> (kg)	Ø Câble <u>Rope ø</u> (mm)	Effort Levier <u>Lever effort</u> (kg)	Avance câble <u>Rope travel</u> (mm)	Dimensions <u>Dimensions</u> (mm)						Poids <u>Weight</u> (kg)
						a	b	c	d	e	f	
200 661	200 546	800	8.4	28	52	22.0	425	170	230	65	59	6.1
200 659	200 544	1600	11.0	4	55	24.5	545	190	270	95	72	11.9
200 660	200 545	3200	16.1	44	28	29.5	660	220	325	116	94	21.1